

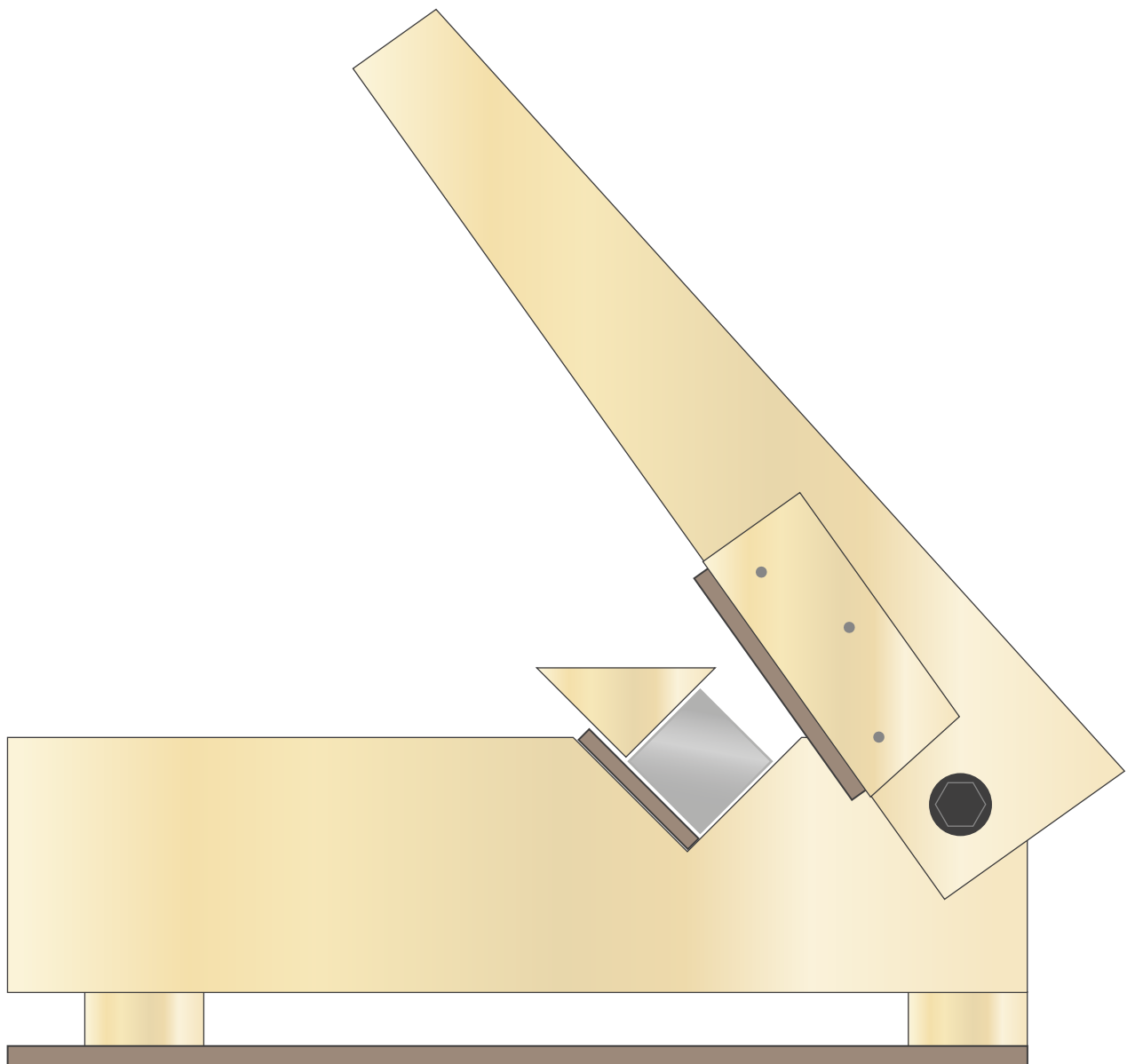

supermagnete

Magnet-Trenner

Bauanleitung



Einkaufsliste







Holz

- 2 x Sperrholz 15 x 60 x 2.4 cm
- 1 x Sperrholz 30 x 60 x 2.4 cm
- 1 x MDF Hartfaserplatte 60 x 60 x 0.8 cm



Kleisenwaren

(ACHTUNG: *nicht* ferromagnetische Teile wählen)

- 13 x Holz-Schraube Edelstahl (Senkkopf) - 4.5 x 45 mm
 (H)
- 12 x Holz-Schraube Edelstahl (Senkkopf) - 3.5 x 35 mm
 (I)
- 1 x Sechskantschraube (oder ähnlich) Edelstahl - M8 x 100 mm
 (J)
- 1 x Sicherheitsmutter - M8
 (K)
- 2 x Unterlegscheibe - M8
 (L)

Diverses

- 1 x Metallband selbstklebend - ca. 1 m ([M-FERROTAPE](#)) (M)
- 1 x UHU Max Repair Kleber ([WS-ADH-01](#)) (N)
- 1 x weicher Schwamm ca. 20 x 15 x 5 cm (O)



Werkzeug

- 1 x Bleistift
- 1 x Massstab/Klappmeter
- 1 x Schutzhandschuhe
- 1 x Schutzbrille
- 2 x Schraubzwinde (15-30 cm)
- 1 x Stichsäge mit Sägeblatt für Holz (Alternative: Handsäge)
- 1 x Akku-Bohrschrauber mit folgenden Aufsätzen:
 - Holzbohrer 8 mm (für grosses Loch)
 - Holzbohrer 6 mm (zum Versenken der Schraubenköpfe)
 - Holzbohrer 5 mm (zum Versenken der Schraubenköpfe)
 - Bits: passend zu gewählten Holzschrauben
- 1 x grobes Schleifpapier
- 1 x feines Schleifpapier
- 1 x Schere



1



60 cm

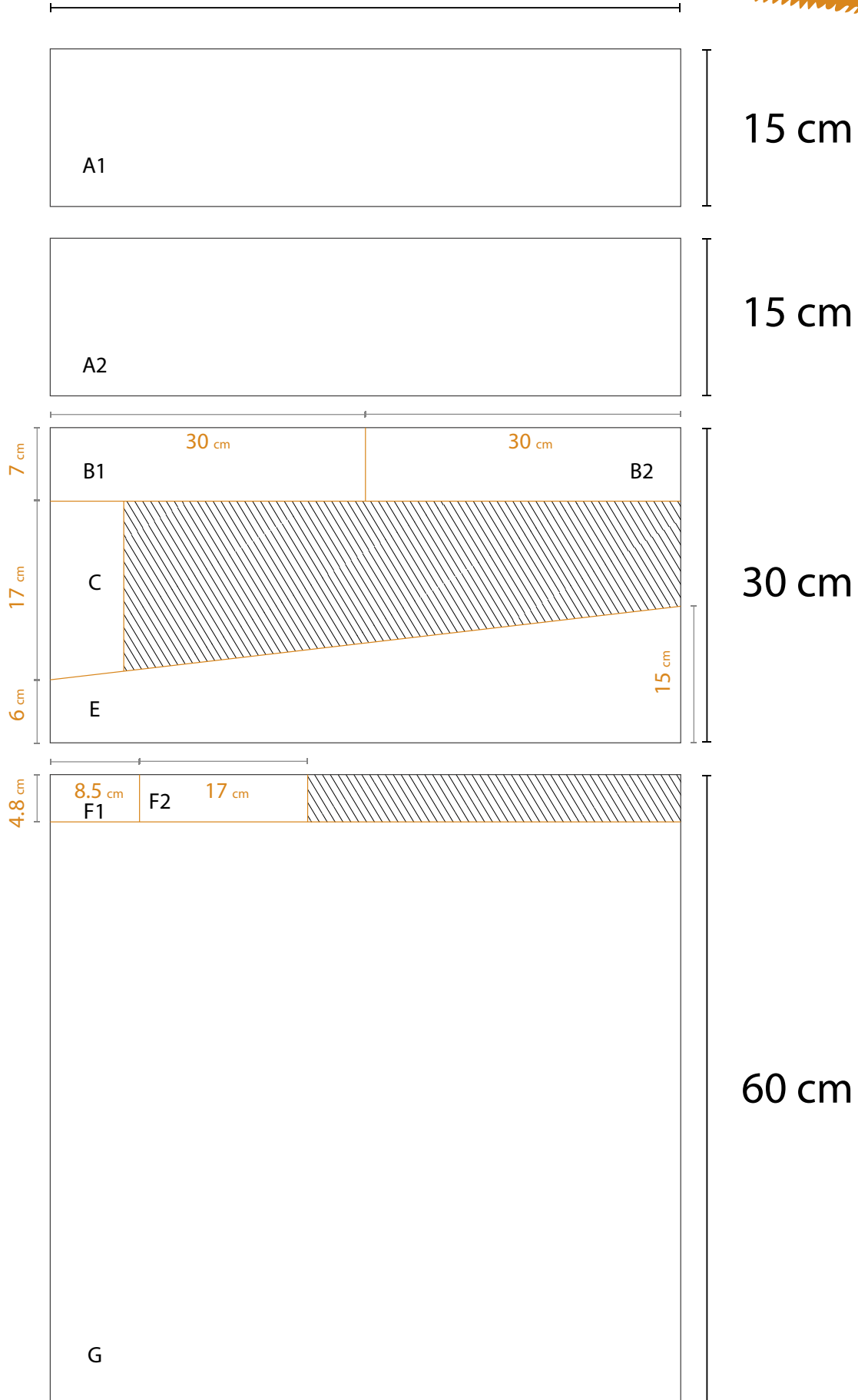
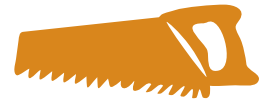

2

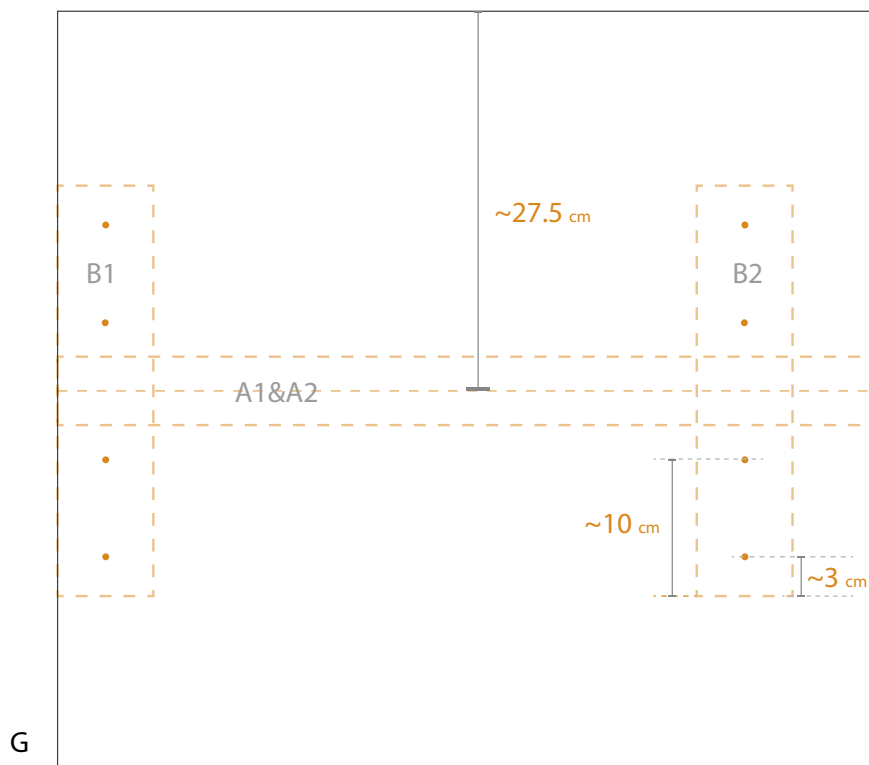
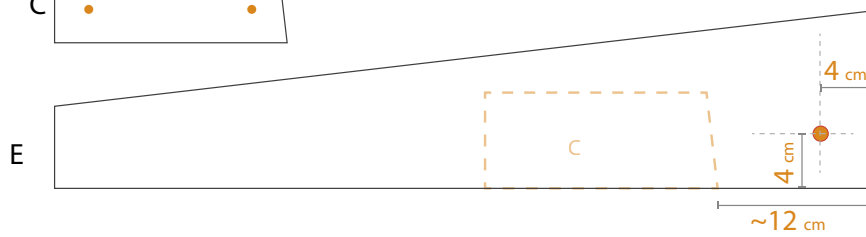
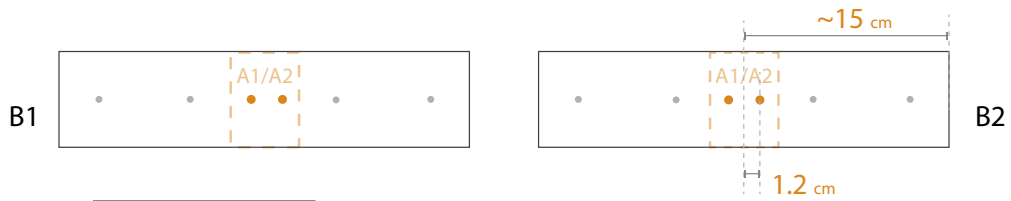
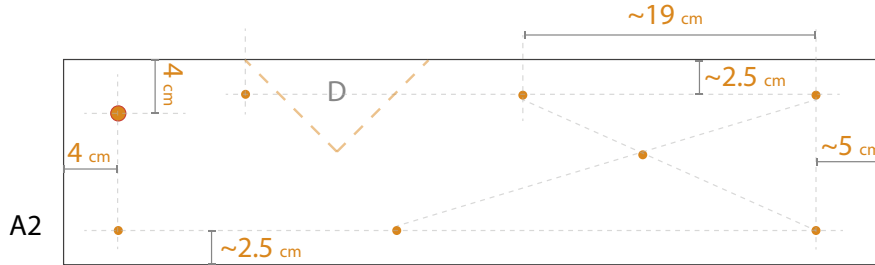
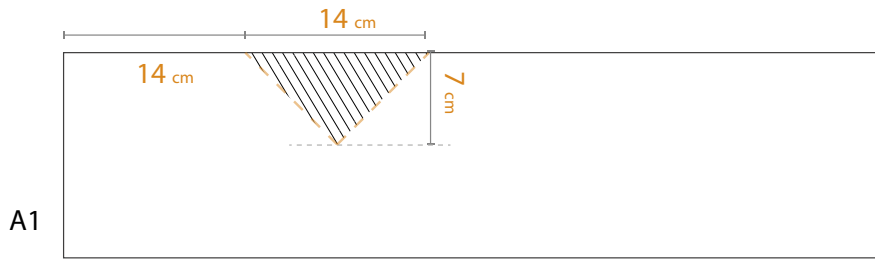



3

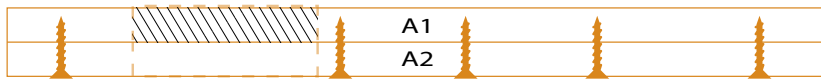
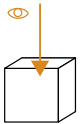
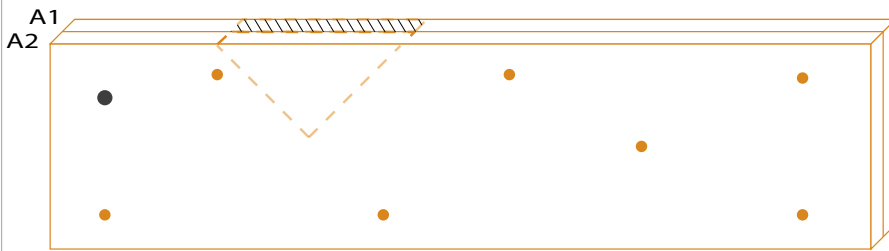
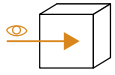

4

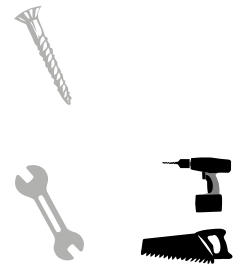
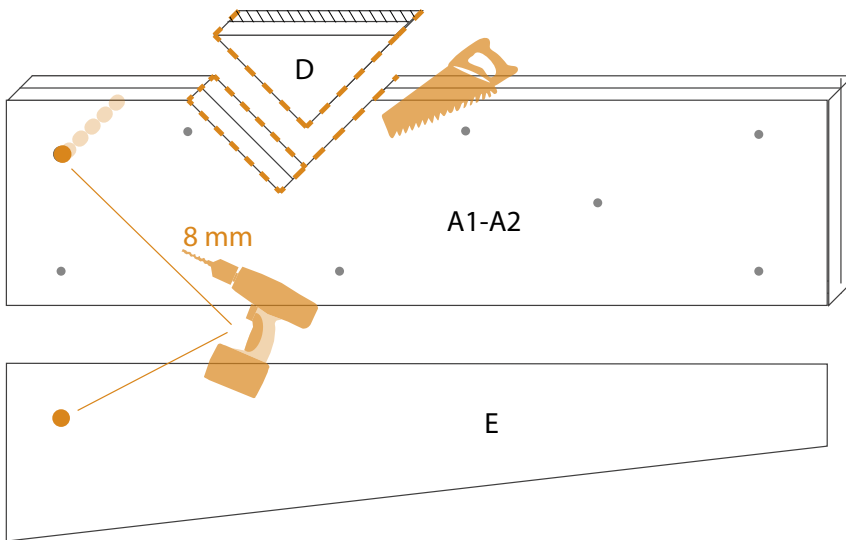
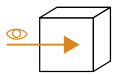

5

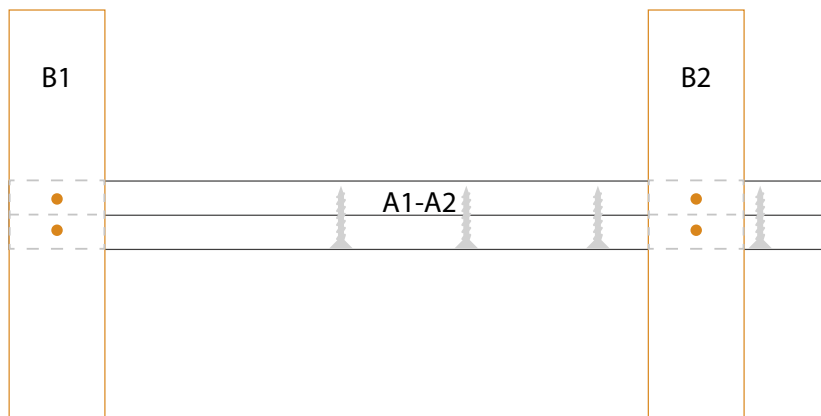
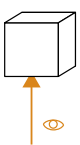
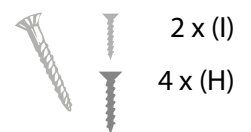
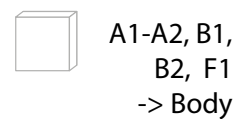
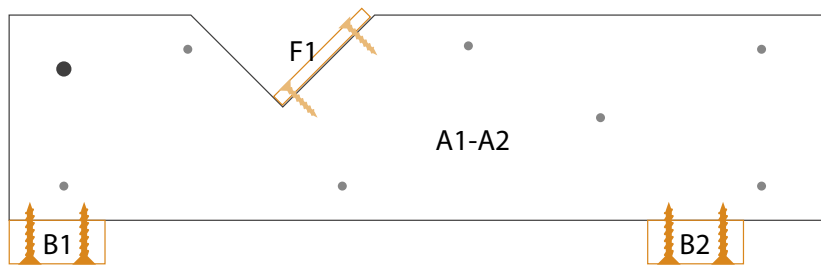
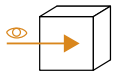

6

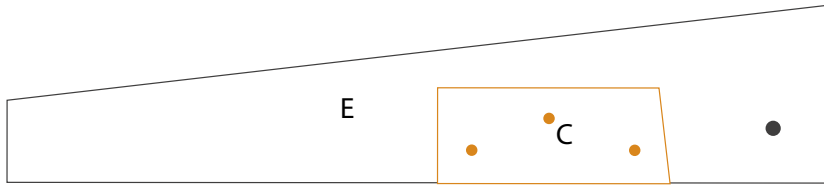
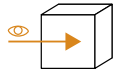

C, E



3 x (H)

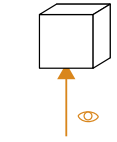

7

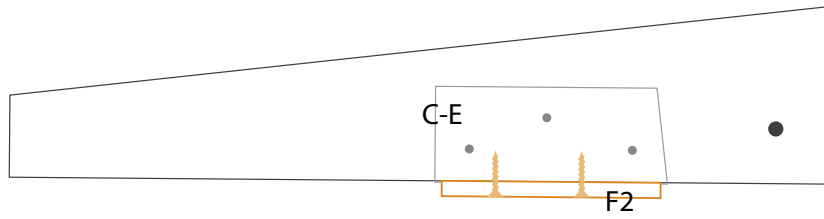
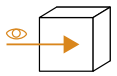

C-E, F2
-> Arm



2 x (I)



8

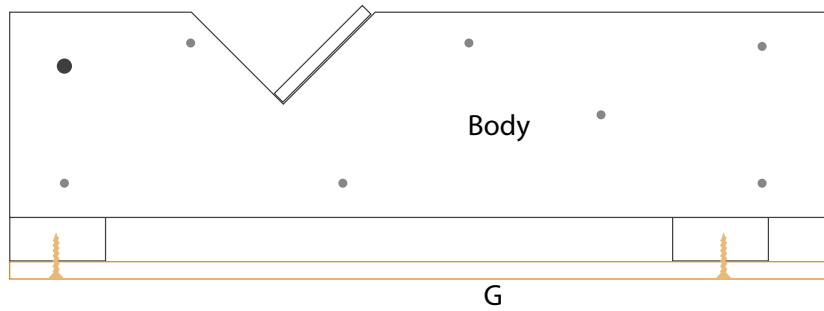
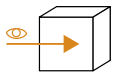

Body, G



8 x (I)

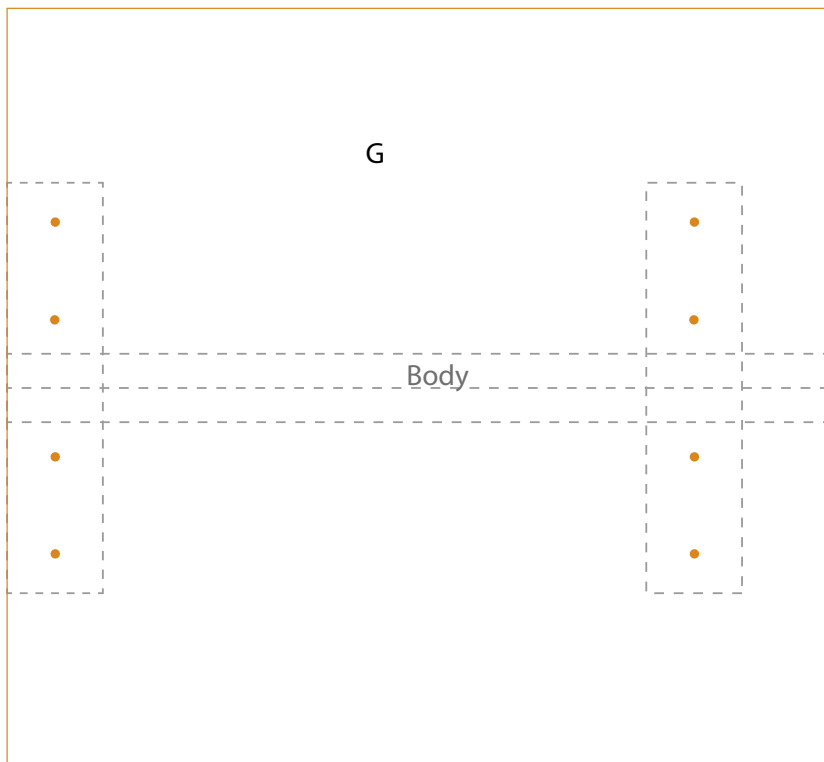
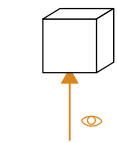

9

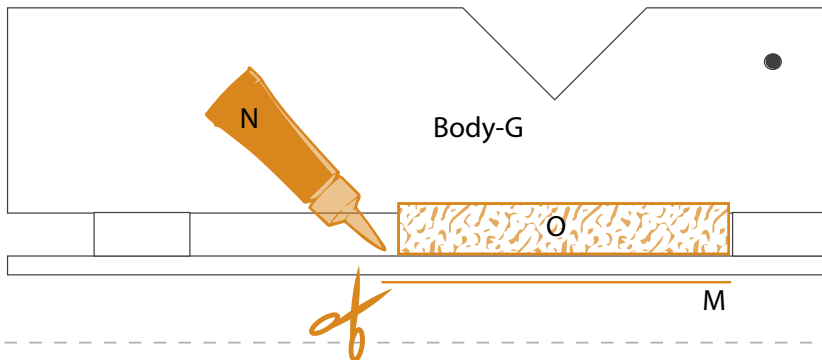
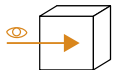

Body-G



1 x (O)

1 x (M)

1 x (N)

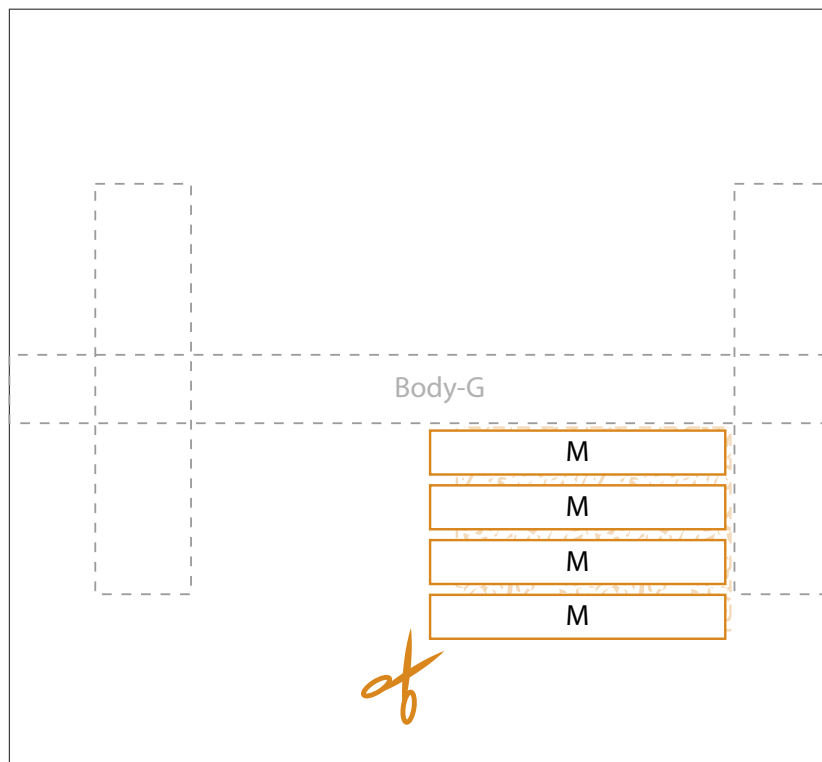
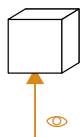

10

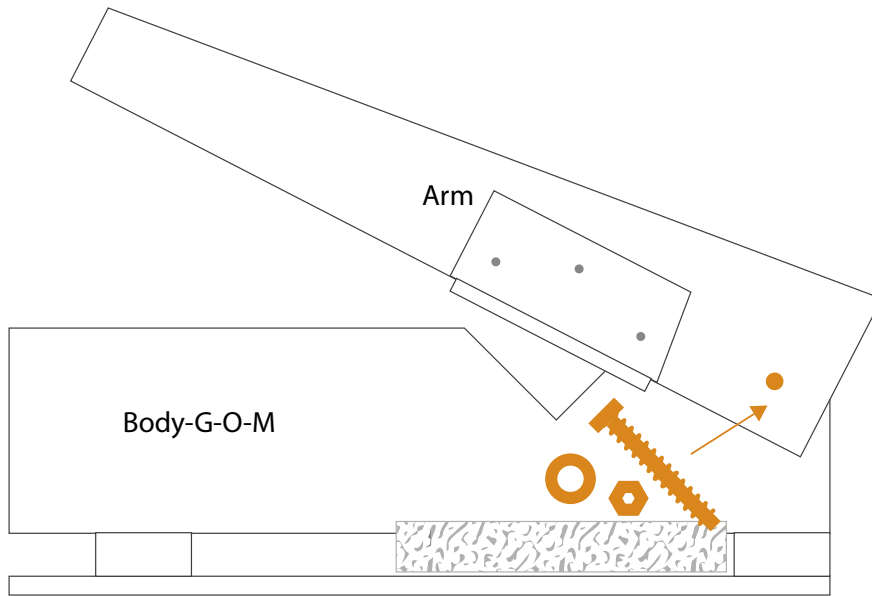
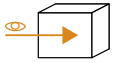

 Body-G-O-M,
Arm

 1 x (K)
 2 x (L)

 1 x (J)

